

Project: _____
 Fixture Type: _____ Quantity: _____
 Customer: _____

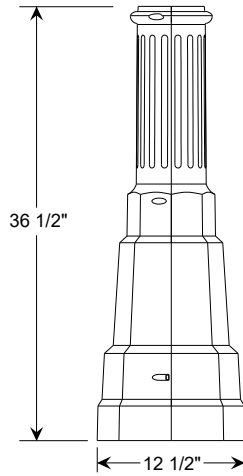

Specifications

Material:
 All parts are durable 356 cast aluminum. All hardware provided shall be stainless steel or zinc plated steel.

Available with aluminum bolt down fluted or smooth; direct burial fluted or smooth; or round steel poles. For tapered poles consult factory.

Fits pole diameters: 3", 4" and 5".



Finish:
 A polyester powder coat high quality finish is electro-statically applied and baked at 430° for exceptional durability and color retention. Products undergo an intensive five-step cleansing and pretreatment process for maximum paint adhesion.

Marine grade finish provides superior salt, humidity and UV protection. This coating withstands up to 3000 hours of continuous salt spray, comes with a 5-year warranty and is available in either a textured or gloss surface.

Modifications:
 Consult factory for custom or modified cast clam shell.

CCS1606

Weight: 26.5 lbs.

Catalog Logic

CCS1606 - **BD4S14.188** - **GFI20** - **72**

Cast Clam Shell Pole Accessory Finish

Catalog Number

1 — **CCS1606** — **2** — **3**

1 POLES

SELECT POLE PART NUMBER FROM SPECS ON PAGES 2 THRU 6.

2 ACCESSORIES

GFI15 (15 Amp GFCI receptacle outlet)

GFI20 (20 Amp GFCI receptacle outlet)

GFI-WPU (20 Amp GFCI receptacle with weather proof in-use cover)

BAA (Cast Banner Arm A for 24" wide banner)

BAB (Cast Banner Arm B for 30" wide banner)

BAC (Cast Banner Arm C for 30" wide banner)

LR1 (Cast Ladder Rest 1)

LR3 (Cast Ladder Rest 3)

LR4 (Cast Ladder Rest 4)

LR5 (Cast Ladder Rest 5)

SIGN A (Cast Sign A; 30" x 9", 8 letters/numbers on one line; requires Banner Arm to hang)

SIGN B (Cast Sign B; 31" x 7", 12 letters/numbers on one line; requires Banner Arm to hang)

SIGN C (Cast Sign C; 27" x 11", two rows of 8 letters/numbers on each line, requires Banner Arm to hang)

SIGN D (Cast Sign D; 11" x 6 1/2", 4 letters/numbers on one line)

SIGN E (Cast Sign E; comes with pole clamp, 24 1/2" x 6", 9 letters/numbers on one line)

FPH1 (Flag Pole Holder)

TP (Tamper Proof Screws)

3 FINISHES

*Premium and Marine Grade Finish have additional charges

Standard Colors	Standard Grade	Marine Grade*	Standard Colors	Standard Grade	Marine Grade*
Aspen Green	10	10M	Architectural Bronze	51	51M
Cantaloupe	11	11M	Patina Verde	52	52M
Lilac	12	12M	Copper Clay	53	53M
Putty	13	13M	Silver	56	56M
Raw Unfinished	40	NA	Black Verde	61	61M
Black	41	41M	Painted Chrome	70	70M
Forest Green	42	42M	Painted Copper	71	71M
Bright Red	43	43M	Textured Black	72	72M
White	44	44M	Matte Black	73	73M
Bright Blue	45	45M	Textured Architectural Bronze	76	76M
Sunny Yellow	46	46M	Textured White	77	77M
Aqua Green	47	47M	Textured Silver	78	78M
Galvanized	49	NA		Premium Grade*	Marine Grade*
Navy	50	50M	Carbon Graphite	96	96M

Consult Factory for additional paint charges and availability.

Project: _____

Fixture Type: _____ Quantity: _____

Customer: _____

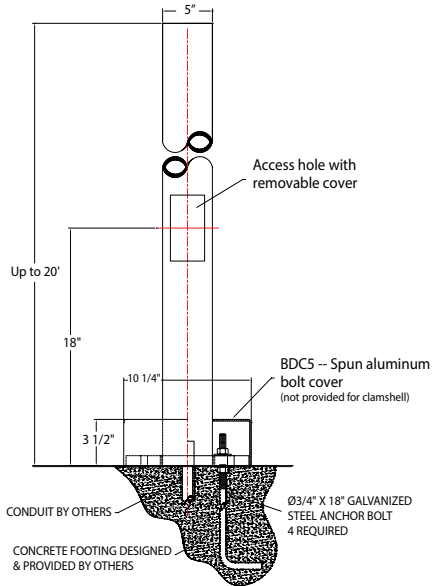

Mounting slot for $\varnothing 3/4"$ anchor bolt. 4 required

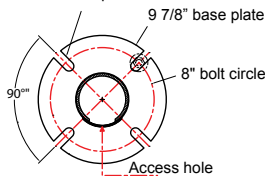

MOUNTING DETAIL

Various heights and fixture configurations may require a different bolt circle. Consult factory for specific bolt circle required.

SMOOTH BOLT DOWN POLE OPTIONS

Item Number	OD	Height	Wall	80 MPH	100 MPH
BD3S3	3	3	0.125	10.10	6.10
BD3S4	3	4	0.125	9.20	5.30
BD3S5	3	5	0.125	8.00	4.70
BD3S6	3	6	0.125	6.90	4.00
BD3S7	3	7	0.125	6.00	3.60
BD3S8	3	8	0.125	5.20	3.00
BD3S9	3	9	0.125	4.50	2.60
BD3S10	3	10	0.125	3.90	2.00
BD3S11	3	11	0.125	3.40	1.70
BD3S12	3	12	0.125	2.90	1.30
BD4S3	4	3	0.125	27.60	14.10
BD4S4	4	4	0.125	23.80	13.00
BD4S5	4	5	0.125	20.70	11.40
BD4S6	4	6	0.125	17.80	9.70
BD4S7	4	7	0.125	15.60	8.50
BD4S8	4	8	0.125	13.40	7.30
BD4S9	4	9	0.125	11.70	6.40
BD4S10	4	10	0.125	10.10	5.60
BD4S11	4	11	0.125	8.80	4.80
BD4S12	4	12	0.125	7.60	3.80
BD4S13	4	13	0.125	6.40	3.30
BD4S14	4	14	0.125	5.70	2.70
BD4S5	4	5	0.188	36.60	19.30
BD4S6	4	6	0.188	31.70	16.80
BD4S7	4	7	0.188	27.60	14.80
BD4S8	4	8	0.188	24.3	13.4
BD4S9	4	9	0.188	21.1	11.9
BD4S10	4	10	0.188	18.0	9.8
BD4S11	4	11	0.188	15.60	8.30
BD4S12	4	12	0.188	13.50	7.40
BD4S13	4	13	0.188	11.40	6.20
BD4S14	4	14	0.188	10.10	5.00
BD4S15	4	15	0.188	8.50	4.70
BD4S16	4	16	0.188	7.60	4.00
BD5S6	5	6	0.125	30.10	18.30
BD5S7	5	7	0.125	26.50	16.20
BD5S8	5	8	0.125	23.00	13.90
BD5S9	5	9	0.125	20.10	12.20
BD5S10	5	10	0.125	17.20	10.40
BD5S11	5	11	0.125	15.00	9.10
BD5S12	5	12	0.125	12.90	7.80
BD5S13	5	13	0.125	11.30	6.70
BD5S14	5	14	0.125	9.70	5.90
BD5S15	5	15	0.125	8.50	5.10
BD5S16	5	16	0.125	7.30	4.40
BD5S17	5	17	0.125	6.40	3.70
BD5S18	5	18	0.125	5.50	3.30
BD5S19	5	19	0.125	4.80	2.90
BD5S20	5	20	0.125	4.10	2.50
BD5S7	5	7	0.188	35.30	21.60
BD5S8	5	8	0.188	30.60	18.50
BD5S9	5	9	0.188	26.80	16.00
BD5S10	5	10	0.188	22.90	13.90
BD5S11	5	11	0.188	19.70	12.20
BD5S12	5	12	0.188	16.80	10.40
BD5S13	5	13	0.188	14.80	8.90
BD5S14	5	14	0.188	12.90	7.60
BD5S15	5	15	0.188	11.30	6.80
BD5S16	5	16	0.188	9.70	5.80
BD5S17	5	17	0.188	8.50	4.90
BD5S18	5	18	0.188	7.40	4.40
BD5S19	5	19	0.188	6.40	3.80
BD5S20	5	20	0.188	5.50	3.30

Material

Aluminum pole bases and base plates shall be cast from 356 aluminum alloy. Shafts shall be extruded 6061-T6 aluminum. Available in 3", 4", or 5" diameter. Wall thickness 0.125" or 0.188".

Mounting

Four anchor bolts provided are 3/4"x18". Anchor bolts, nuts and washers are hot dipped galvanized steel. Spun aluminum bolt cover provided.

Access

All poles are provided with a hand access opening and cover. Hand hole cover is secured by two stainless steel machine screws. (Tamper-proof screws provided upon request).

Grounding

All poles are provided with an aluminum grounding lug integrated to inner wall of shaft, 180 degrees to hand hole. Grounding lug is drilled and tapped to accommodate 1/4"-20 stainless steel machine screw.

Pole Height

Maximum pole height is 20-feet.

Accessories

Banner arms, ladder rests, signage, flag pole holder and GFI receptacles are optional.

Finish

A polyester powder coat high quality finish is electro-statically applied and baked at 430° for exceptional durability and color retention. Products undergo an intensive five-step cleansing and pretreatment process for maximum paint adhesion.

Marine grade finish provides superior salt, humidity, and UV protection. This coating withstands up to 3000 hours of continuous salt spray, comes with a 5-year warranty and is available in either a textured or gloss surface.

Project: _____

Fixture Type: _____ Quantity: _____

Customer: _____

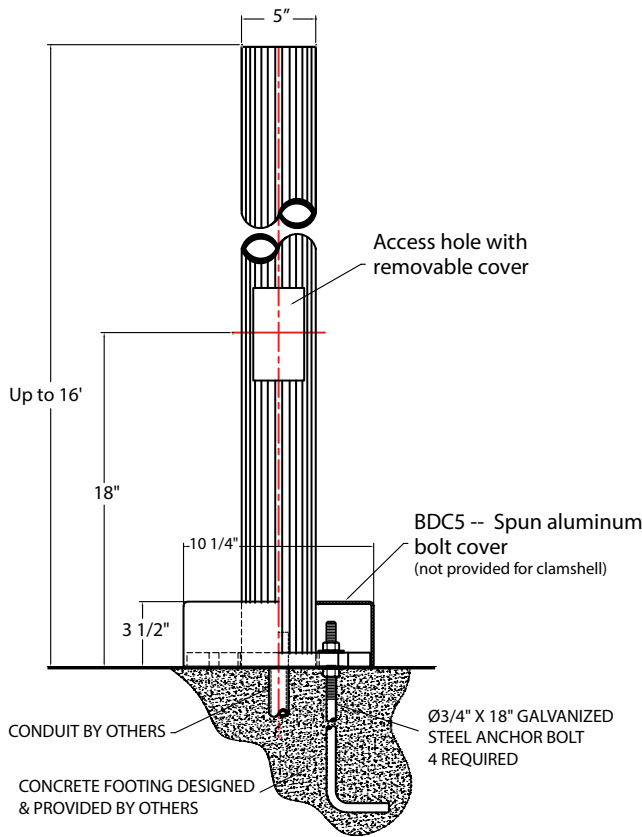

FLUTED BOLT DOWN POLE OPTIONS			
Item Number	OD	Height	Wall
BD3F6-.125	3.00"	6'	.125
BD3F7-.125	3.00"	7'	.125
BD3F8-.125	3.00"	8'	.125
BD3F9-.125	3.00"	9'	.125
BD3F10-.125	3.00"	10'	.125
BD4F8-.188	4.00"	8'	.188
BD4F9-.188	4.00"	9'	.188
BD4F10-.188	4.00"	10'	.188
BD4F11-.188	4.00"	11'	.188
BD4F12-.188	4.00"	12'	.188
BD4F13-.188	4.00"	13'	.188
BD4F14-.188	4.00"	14'	.188
BD5F10-.188	5.00"	10'	.188
BD5F11-.188	5.00"	11'	.188
BD5F12-.188	5.00"	12'	.188
BD5F13-.188	5.00"	13'	.188
BD5F14-.188	5.00"	14'	.188
BD5F15-.188	5.00"	15'	.188
BD5F16-.188	5.00"	16'	.188

Mounting slot for Ø3/4" anchor bolt. 4 required

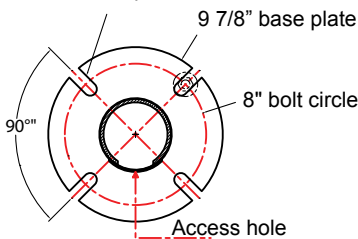

MOUNTING DETAIL

Various heights and fixture configurations may require a different bolt circle. Consult factory for specific bolt circle required.

Material

Aluminum pole bases and base plates shall be cast from 356 aluminum alloy. Shafts shall be extruded 6061-T6 aluminum. Available in 3", 4", or 5" diameter. Wall thickness 0.125" or 0.188".

Mounting

Four anchor bolts provided are 3/4"x18". Anchor bolts, nuts and washers are hot dipped galvanized steel. Spun aluminum bolt cover provided.

Access

All poles are provided with a hand access opening and cover. Hand hole cover is secured by two stainless steel machine screws. (Tamper-proof screws provided upon request) 1-1/2"Ø wireway hole provided on same side as access hole

Grounding

All poles are provided with an aluminum grounding lug integrated to inner wall of shaft, 180 degrees to hand hole. Grounding lug is drilled and tapped to accommodate 1/4"-20 stainless steel machine screw.

Pole Height

Maximum pole height is 16-feet.

Accessories

Banner arms, ladder rests, signage, flag pole holder and GFI receptacles are optional.

Finish

A polyester powder coat high quality finish is electro-statically applied and baked at 430° for exceptional durability and color retention. Products undergo an intensive five-step cleansing and pretreatment process for maximum paint adhesion.

Marine grade finish provides superior salt, humidity, and UV protection. This coating withstands up to 3000 hours of continuous salt spray, comes with a 5-year warranty and is available in either a textured or gloss surface.

Project: _____

Fixture Type: _____ Quantity: _____

Customer: _____

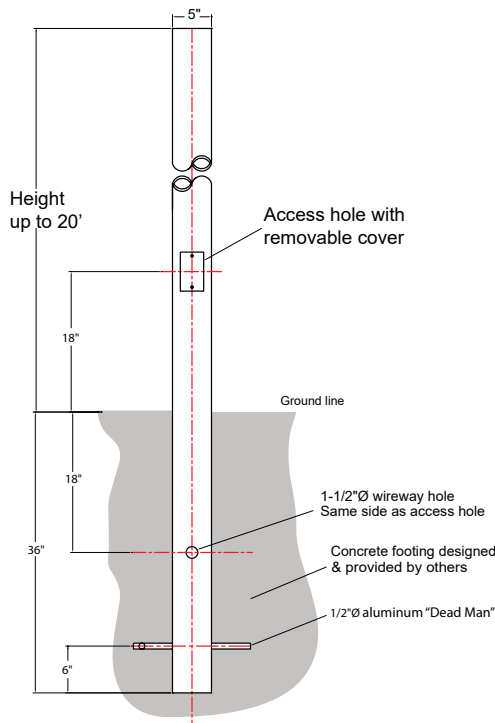

SMOOTH DIRECT BURIAL POLE OPTIONS

Item Number	OD	Height	Wall
DB3S3	3	3	0.125
DB3S4	3	4	0.125
DB3S5	3	5	0.125
DB3S6	3	6	0.125
DB3S7	3	7	0.125
DB3S8	3	8	0.125
DB3S9	3	9	0.125
DB3S10	3	10	0.125
DB3S11	3	11	0.125
DB3S12	3	12	0.125
DB4S3	4	3	0.125
DB4S4	4	4	0.125
DB4S5	4	5	0.125
DB4S6	4	6	0.125
DB4S7	4	7	0.125
DB4S8	4	8	0.125
DB4S9	4	9	0.125
DB4S10	4	10	0.125
DB4S11	4	11	0.125
DB4S12	4	12	0.125
DB4S13	4	13	0.125
DB4S14	4	14	0.125
DB4S5	4	5	0.188
DB4S6	4	6	0.188
DB4S7	4	7	0.188
DB4S8	4	8	0.188
DB4S9	4	9	0.188
DB4S10	4	10	0.188
DB4S11	4	11	0.188
DB4S12	4	12	0.188
DB4S13	4	13	0.188
DB4S14	4	14	0.188
DB4S15	4	15	0.188
DB4S16	4	16	0.188
DB5S6	5	6	0.125
DB5S7	5	7	0.125
DB5S8	5	8	0.125
DB5S9	5	9	0.125
DB5S10	5	10	0.125
DB5S11	5	11	0.125
DB5S12	5	12	0.125
DB5S13	5	13	0.125
DB5S14	5	14	0.125
DB5S15	5	15	0.125
DB5S16	5	16	0.125
DB5S17	5	17	0.125
DB5S18	5	18	0.125
DB5S19	5	19	0.125
DB5S20	5	20	0.125
DB5S7	5	7	0.188
DB5S8	5	8	0.188
DB5S9	5	9	0.188
DB5S10	5	10	0.188
DB5S11	5	11	0.188
DB5S12	5	12	0.188
DB5S13	5	13	0.188
DB5S14	5	14	0.188
DB5S15	5	15	0.188
DB5S16	5	16	0.188
DB5S17	5	17	0.188
DB5S18	5	18	0.188
DB5S19	5	19	0.188
DB5S20	5	20	0.188

Material

Aluminum pole shall be extruded 6061-T6 aluminum. Available in 3", 4", or 5" diameter. Wall thickness 0.125" or 0.188".

Mounting

Concrete footing designed and provided by others. A 1/2"Ø aluminum "Dead Man" is provided.

Access

All poles are provided with a hand access opening and cover. Hand hole cover is secured by two stainless steel machine screws. (Tamper-proof screws provided upon request). 1-1/2"Ø wireway hole provided on same side as access hole.

Grounding

All poles are provided with an aluminum grounding lug integrated to inner wall of shaft, 180 degrees to hand hole. Grounding lug is drilled and tapped to accommodate 1/4-20 stainless steel machine screw.

Pole Height

Maximum pole height is 20-feet.

Accessories

Banner arms, ladder rests, signage, flag pole holder and GFI receptacles are optional.

Finish

A polyester powder coat high quality finish is electro-statically applied and baked at 430° for exceptional durability and color retention. Products undergo an intensive five-step cleansing and pretreatment process for maximum paint adhesion.

Marine grade finish provides superior salt, humidity, and UV protection. This coating withstands up to 3000 hours of continuous salt spray, comes with a 5-year warranty and is available in either a textured or gloss surface.

Project: _____

Fixture Type: _____ Quantity: _____

Customer: _____

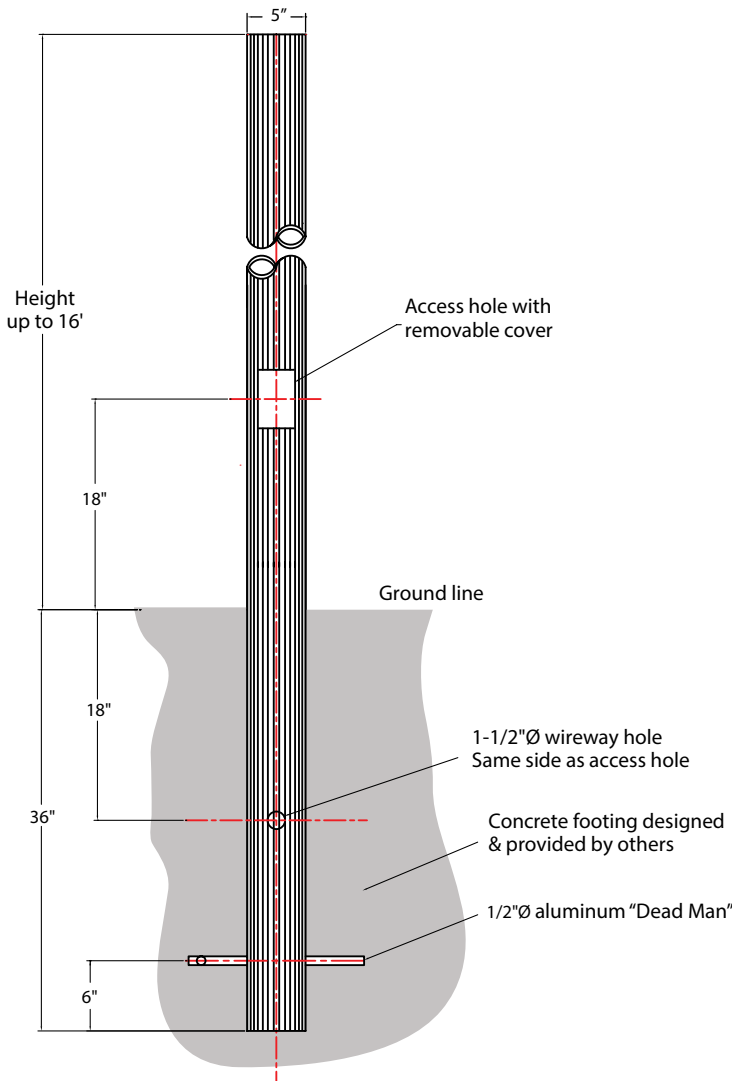

FLUTED DIRECT BURIAL POLE OPTIONS			
Item Number	OD	Height	Wall
DB3F6-.125	3.00"	6'	.125
DB3F7-.125	3.00"	7'	.125
DB3F8-.125	3.00"	8'	.125
DB3F9-.125	3.00"	9'	.125
DB3F10-.125	3.00"	10'	.125
DB4F8-.188	4.00"	8'	.188
DB4F9-.188	4.00"	9'	.188
DB4F10-.188	4.00"	10'	.188
DB4F11-.188	4.00"	11'	.188
DB4F12-.188	4.00"	12'	.188
DB4F13-.188	4.00"	13'	.188
DB4F14-.188	4.00"	14'	.188
DB5F10-.188	5.00"	10'	.188
DB5F11-.188	5.00"	11'	.188
DB5F12-.188	5.00"	12'	.188
DB5F13-.188	5.00"	13'	.188
DB5F14-.188	5.00"	14'	.188
DB5F15-.188	5.00"	15'	.188
DB5F16-.188	5.00"	16'	.188

Material

Aluminum pole shall be extruded 6061-T6 aluminum. Available in 3", 4", or 5" diameter. Wall thickness 0.125" or 0.188".

Mounting

Concrete footing designed and provided by others. A 1/2"Ø aluminum "Dead Man" is provided.

Access

All poles are provided with a hand access opening and cover. Hand hole cover is secured by two stainless steel machine screws. (Tamper-proof screws provided upon request) 1-1/2"Ø wireway hole provided on same side as access hole

Grounding

All poles are provided with an aluminum grounding lug integrated to inner wall of shaft, 180 degrees to hand hole. Grounding lug is drilled and tapped to accommodate ¼-20 stainless steel machine screw.

Pole Height

Maximum pole height is 16-feet.

Accessories

Banner arms, ladder rests, signage, flag pole holder and GFI receptacles are optional.

Finish

A polyester powder coat high quality finish is electro-statically applied and baked at 430° for exceptional durability and color retention. Products undergo an intensive five-step cleansing and pretreatment process for maximum paint adhesion.

Marine grade finish provides superior salt, humidity, and UV protection. This coating withstands up to 3000 hours of continuous salt spray, comes with a 5-year warranty and is available in either a textured or gloss surface.

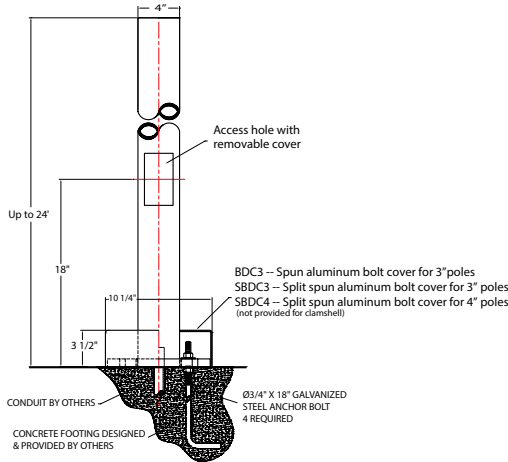

Project: _____
 Fixture Type: _____ Quantity: _____
 Customer: _____

SMOOTH STEEL BOLT DOWN POLE OPTIONS			
Item Number	OD	Height	Wall
BD3STLS8-11	3.00"	8'	11g
BD3STLS10-11	3.00"	10'	11g
BD3STLS12-11	3.00"	12'	11g
BD3STLS14-11	3.00"	14'	11g
BD3STLS16-11	3.00"	16'	11g
BD3STLS18-11	3.00"	18'	11g
BD3STLS20-11	3.00"	20'	11g
BD3STLS8-7	3.00"	8'	7g
BD3STLS10-7	3.00"	10'	7g
BD3STLS12-7	3.00"	12'	7g
BD3STLS14-7	3.00"	14'	7g
BD3STLS16-7	3.00"	16'	7g
BD3STLS18-7	3.00"	18'	7g
BD3STLS20-7	3.00"	20'	7g
BD3STLS22-7	3.00"	22'	7g
BD3STLS24-7	3.00"	24'	7g
BD4STLS8-11	4.00"	8'	11g
BD4STLS10-11	4.00"	10'	11g
BD4STLS12-11	4.00"	12'	11g
BD4STLS14-11	4.00"	14'	11g
BD4STLS16-11	4.00"	16'	11g
BD4STLS18-11	4.00"	18'	11g
BD4STLS20-11	4.00"	20'	11g
BD4STLS8-7	4.00"	8'	7g
BD4STLS10-7	4.00"	10'	7g
BD4STLS12-7	4.00"	12'	7g
BD4STLS14-7	4.00"	14'	7g
BD4STLS16-7	4.00"	16'	7g
BD4STLS18-7	4.00"	18'	7g
BD4STLS20-7	4.00"	20'	7g
BD4STLS22-7	4.00"	22'	7g
BD4STLS24-7	4.00"	24'	7g

Mounting slot for Ø3/4" anchor bolt. 4 required

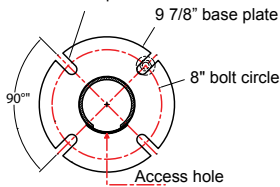

MOUNTING DETAIL

Various heights and fixture configurations may require a different bolt circle. Consult factory for specific bolt circle required.

Material

One-piece non-tapered round shaft of low carbon steel (ASTM-A500 Grade B, 42,000 PSI min. yield) with one flush-welded vertical seam. Shaft is welded to a flat steel anchor base (ASTM-36, 36,000 PSI min. yield). Wall thickness is 11 gauge or 7 gauge.

Mounting

Four anchor bolts provided are 3/4"x18". Anchor bolts, nuts and washers are hot dipped galvanized steel. Spun aluminum bolt cover provided.

Access

All poles are provided with a hand access opening and cover. Hand hole cover is secured by two stainless steel machine screws. (Tamper-proof screws provided upon request).

Grounding

All poles are provided with an aluminum grounding lug integrated to inner wall of shaft, 180 degrees to hand hole. Grounding lug is drilled and tapped to accommodate 1/4-20 stainless steel machine screw.

Pole Height

Maximum pole height is 24-feet.

Accessories

Banner arms, ladder rests, signage, flag pole holder and GFI receptacles are optional.

Finish

A polyester powder coat high quality finish is electro-statically applied and baked at 430° for exceptional durability and color retention. Products undergo an intensive five-step cleansing and pretreatment process for maximum paint adhesion. Marine grade finish provides superior salt, humidity, and UV protection. This coating withstands up to 3000 hours of continuous salt spray, comes with a 5-year warranty and is available in either a textured or gloss surface.