

Project: _____
 Fixture Type: _____ Quantity: _____
 Customer: _____

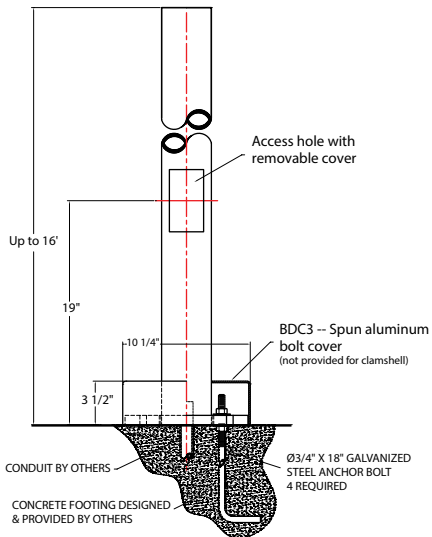

Mounting slot for Ø1/2" anchor bolt. 4 required

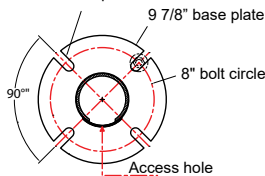

MOUNTING DETAIL

Various heights and fixture configurations may require a different bolt circle. Consult factory for specific bolt circle required.

SMOOTH BOLT DOWN POLE OPTIONS					
Item Number	OD	Height	Wall	80 MPH	100 MPH
BD3S3	3	3	0.125	10.10	6.10
BD3S4	3	4	0.125	9.20	5.30
BD3S5	3	5	0.125	8.00	4.70
BD3S6	3	6	0.125	6.90	4.00
BD3S7	3	7	0.125	6.00	3.60
BD3S8	3	8	0.125	5.20	3.00
BD3S9	3	9	0.125	4.50	2.60
BD3S10	3	10	0.125	3.90	2.00
BD3S11	3	11	0.125	3.40	1.70
BD3S12	3	12	0.125	2.90	1.30
BD4S3	4	3	0.125	27.60	14.10
BD4S4	4	4	0.125	23.80	13.00
BD4S5	4	5	0.125	20.70	11.40
BD4S6	4	6	0.125	17.80	9.70
BD4S7	4	7	0.125	15.60	8.50
BD4S8	4	8	0.125	13.40	7.30
BD4S9	4	9	0.125	11.70	6.40
BD4S10	4	10	0.125	10.10	5.60
BD4S11	4	11	0.125	8.80	4.80
BD4S12	4	12	0.125	7.60	3.80
BD4S13	4	13	0.125	6.40	3.30
BD4S14	4	14	0.125	5.70	2.70
BD4S5	4	5	0.188	36.60	19.30
BD4S6	4	6	0.188	31.70	16.80
BD4S7	4	7	0.188	27.60	14.80
BD4S8	4	8	0.188	24.3	13.4
BD4S9	4	9	0.188	21.1	11.9
BD4S10	4	10	0.188	18.0	9.8
BD4S11	4	11	0.188	15.60	8.30
BD4S12	4	12	0.188	13.50	7.40
BD4S13	4	13	0.188	11.40	6.20
BD4S14	4	14	0.188	10.10	5.00
BD4S15	4	15	0.188	8.50	4.70
BD4S16	4	16	0.188	7.60	4.00

Material

Aluminum pole bases and base plates shall be cast from 356 aluminum alloy. Shafts shall be extruded 6061-T6 aluminum. Available in 3" or 4" diameter. Wall thickness 0.125".

Mounting

Four anchor bolts provided are 1/2"x18" or 3/4"x18" depending on the pole height, fixture weight and mounting weight. Anchor bolts, nuts and washers are hot dipped galvanized steel. Spun aluminum bolt cover provided.

Access

All poles are provided with a hand access opening and cover. Hand hole cover is secured by two stainless steel machine screws. (Tamper-proof screws provided upon request).

Grounding

All poles are provided with an aluminum grounding lug integrated to inner wall of shaft, 180 degrees to hand hole. Grounding lug is drilled and tapped to accommodate 1/4-20 stainless steel machine screw.

Pole Height

Maximum pole height is 16-feet.

Accessories

Banner arms, ladder rests, signage, flag pole holder and GFI receptacles are optional.

Finish

A polyester powder coat high quality finish is electro-statically applied and baked at 430° for exceptional durability and color retention. Products undergo an intensive five-step cleansing and pretreatment process for maximum paint adhesion.

Marine grade finish provides superior salt, humidity, and UV protection. This coating withstands up to 3000 hours of continuous salt spray, comes with a 5-year warranty and is available in either a textured or gloss surface.

Project: _____

Fixture Type: _____ Quantity: _____

Customer: _____

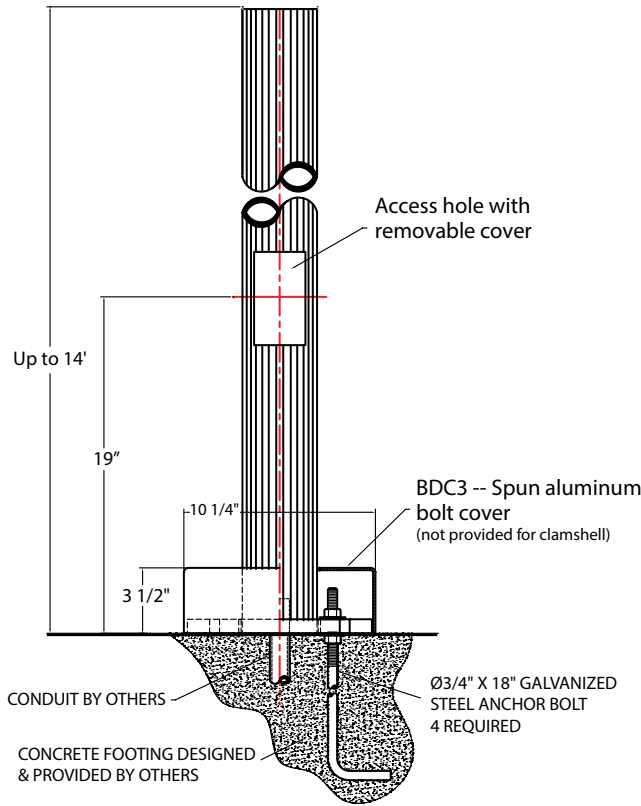

FLUTED BOLT DOWN POLE OPTIONS			
Item Number	OD	Height	Wall
DB3F6-.125	3.00"	6'	.125
DB3F7-.125	3.00"	7'	.125
DB3F8-.125	3.00"	8'	.125
DB3F9-.125	3.00"	9'	.125
DB3F10-.125	3.00"	10'	.125
DB4F8-.188	4.00"	8'	.188
DB4F9-.188	4.00"	9'	.188
DB4F10-.188	4.00"	10'	.188
DB4F11-.188	4.00"	11'	.188
DB4F12-.188	4.00"	12'	.188
DB4F13-.188	4.00"	13'	.188
DB4F14-.188	4.00"	14'	.188

Mounting slot for Ø1/2" anchor bolt. 4 required

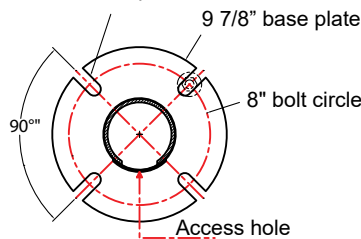

MOUNTING DETAIL

Various heights and fixture configurations may require a different bolt circle. Consult factory for specific bolt circle required.

Material

Aluminum pole bases and base plates shall be cast from 356 aluminum alloy. Shafts shall be extruded 6061-T6 aluminum. Available in 3" or 4" diameter. Wall thickness 0.125".

Mounting

Four anchor bolts provided are 1/2"x18" or 3/4"x18" depending on the pole height, fixture weight and mounting weight. Anchor bolts, nuts and washers are hot dipped galvanized steel. Spun aluminum bolt cover provided.

Access

All poles are provided with a hand access opening and cover. Hand hole cover is secured by two stainless steel machine screws. (Tamper-proof screws provided upon request) 1-1/2"Ø wireway hole provided on same side as access hole

Grounding

All poles are provided with an aluminum grounding lug integrated to inner wall of shaft, 180 degrees to hand hole. Grounding lug is drilled and tapped to accommodate 1/4-20 stainless steel machine screw.

Pole Height

Maximum pole height is 10-feet.

Accessories

Banner arms, ladder rests, signage, flag pole holder and GFI receptacles are optional.

Finish

A polyester powder coat high quality finish is electro-statically applied and baked at 430° for exceptional durability and color retention. Products undergo an intensive five-step cleansing and pretreatment process for maximum paint adhesion.

Marine grade finish provides superior salt, humidity, and UV protection. This coating withstands up to 3000 hours of continuous salt spray, comes with a 5-year warranty and is available in either a textured or gloss surface.

Project: _____

Fixture Type: _____ Quantity: _____

Customer: _____

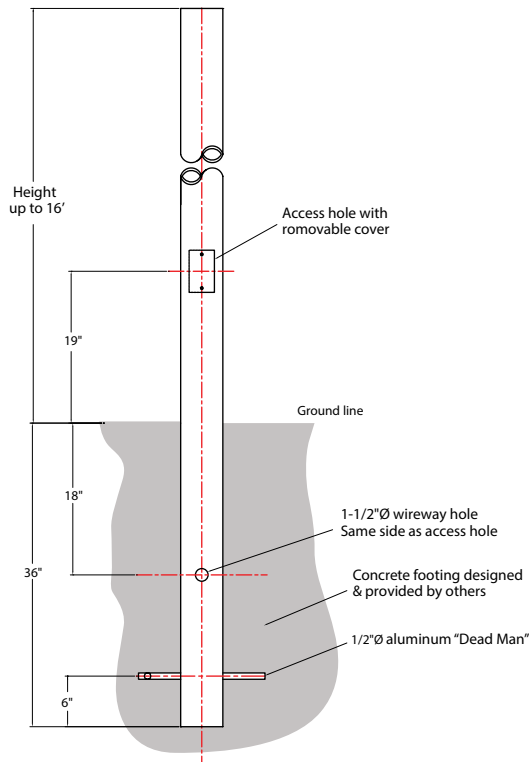

SMOOTH DIRECT BURIAL POLE OPTIONS			
Item Number	OD	Height	Wall
DB3S3	3	3	0.125
DB3S4	3	4	0.125
DB3S5	3	5	0.125
DB3S6	3	6	0.125
DB3S7	3	7	0.125
DB3S8	3	8	0.125
DB3S9	3	9	0.125
DB3S10	3	10	0.125
DB3S11	3	11	0.125
DB3S12	3	12	0.125
DB4S3	4	3	0.125
DB4S4	4	4	0.125
DB4S5	4	5	0.125
DB4S6	4	6	0.125
DB4S7	4	7	0.125
DB4S8	4	8	0.125
DB4S9	4	9	0.125
DB4S10	4	10	0.125
DB4S11	4	11	0.125
DB4S12	4	12	0.125
DB4S13	4	13	0.125
DB4S14	4	14	0.125
DB4S5	4	5	0.188
DB4S6	4	6	0.188
DB4S7	4	7	0.188
DB4S8	4	8	0.188
DB4S9	4	9	0.188
DB4S10	4	10	0.188
DB4S11	4	11	0.188
DB4S12	4	12	0.188
DB4S13	4	13	0.188
DB4S14	4	14	0.188
DB4S15	4	15	0.188
DB4S16	4	16	0.188

Material

Aluminum pole shall be extruded 6061-T6 aluminum. Available in 3" or 4" diameter. Wall thickness 0.125".

Mounting

Concrete footing designed and provided by others. A 1/2"Ø aluminum "Dead Man" is provided.

Access

All poles are provided with a hand access opening and cover. Hand hole cover is secured by two stainless steel machine screws. (Tamper-proof screws provided upon request). 1-1/2"Ø wireway hole provided on same side as access hole.

Grounding

All poles are provided with an aluminum grounding lug integrated to inner wall of shaft, 180 degrees to hand hole. Grounding lug is drilled and tapped to accommodate 1/4-20 stainless steel machine screw.

Pole Height

Maximum pole height is 16-feet.

Accessories

Banner arms, ladder rests, signage, flag pole holder and GFI receptacles are optional.

Finish

A polyester powder coat high quality finish is electro-statically applied and baked at 430° for exceptional durability and color retention. Products undergo an intensive five-step cleansing and pretreatment process for maximum paint adhesion.

Marine grade finish provides superior salt, humidity, and UV protection. This coating withstands up to 3000 hours of continuous salt spray, comes with a 5-year warranty and is available in either a textured or gloss surface.

Project: _____

Fixture Type: _____ Quantity: _____

Customer: _____

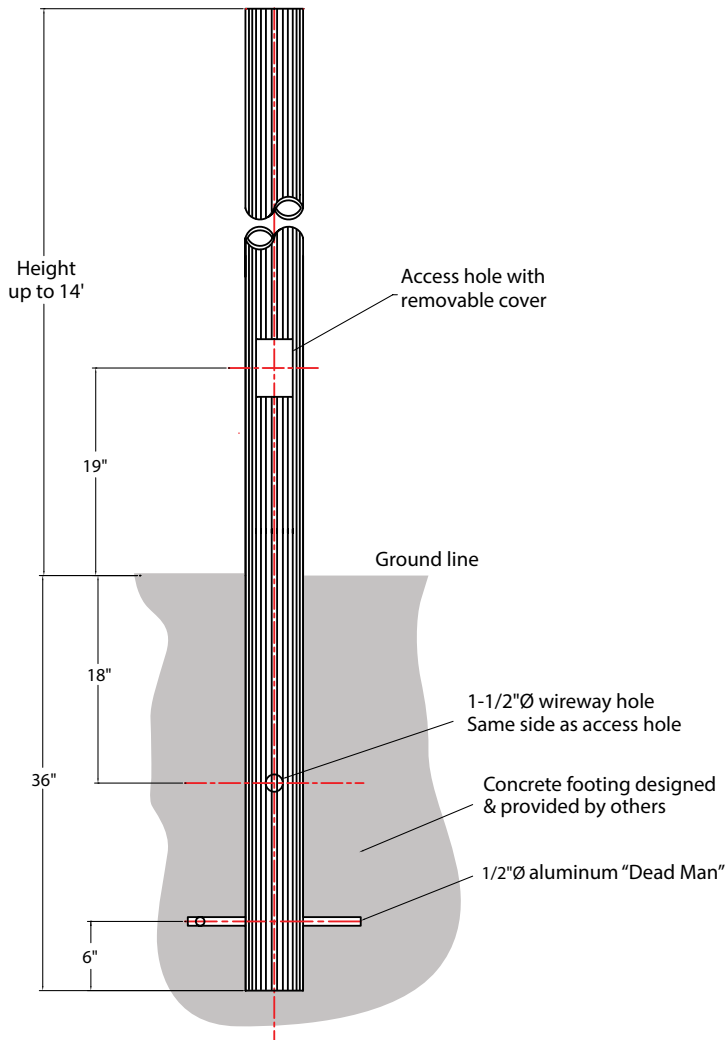

FLUTED DIRECT BURIAL POLE OPTIONS

Item Number	OD	Height	Wall
DB3F6-.125	3.00"	6'	.125
DB3F7-.125	3.00"	7'	.125
DB3F8-.125	3.00"	8'	.125
DB3F9-.125	3.00"	9'	.125
DB3F10-.125	3.00"	10'	.125
DB4F8-.188	4.00"	8'	.188
DB4F9-.188	4.00"	9'	.188
DB4F10-.188	4.00"	10'	.188
DB4F11-.188	4.00"	11'	.188
DB4F12-.188	4.00"	12'	.188
DB4F13-.188	4.00"	13'	.188
DB4F14-.188	4.00"	14'	.188

Material

Aluminum pole shall be extruded 6061-T6 aluminum. Available in 3" or 4" diameter. Wall thickness 0.125".

Mounting

Concrete footing designed and provided by others. A 1/2"Ø aluminum "Dead Man" is provided.

Access

All poles are provided with a hand access opening and cover. Hand hole cover is secured by two stainless steel machine screws. (Tamper-proof screws provided upon request) 1-1/2"Ø wireway hole provided on same side as access hole

Grounding

All poles are provided with an aluminum grounding lug integrated to inner wall of shaft, 180 degrees to hand hole. Grounding lug is drilled and tapped to accommodate 1/4"-20 stainless steel machine screw.

Pole Height

Maximum pole height is 14-feet.

Accessories

Banner arms, ladder rests, signage, flag pole holder and GFI receptacles are optional.

Finish

A polyester powder coat high quality finish is electro-statically applied and baked at 430° for exceptional durability and color retention. Products undergo an intensive five-step cleansing and pretreatment process for maximum paint adhesion.

Marine grade finish provides superior salt, humidity, and UV protection. This coating withstands up to 3000 hours of continuous salt spray, comes with a 5-year warranty and is available in either a textured or gloss surface.

Project: _____
 Fixture Type: _____ Quantity: _____
 Customer: _____

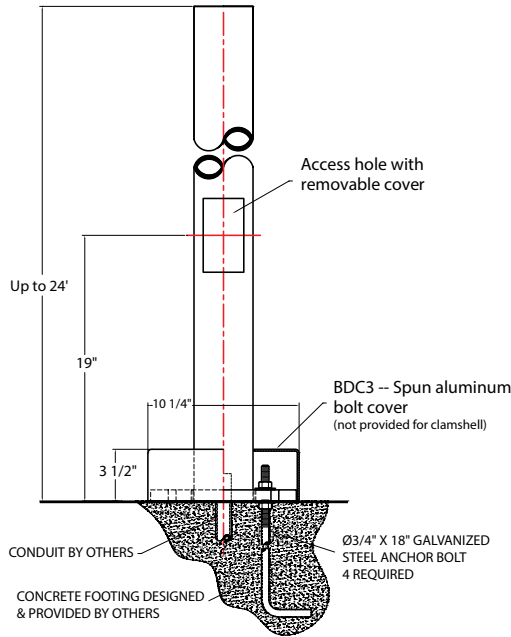

Mounting slot for Ø1/2" anchor bolt. 4 required

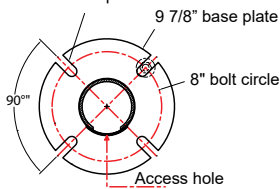

MOUNTING DETAIL

Various heights and fixture configurations may require a different bolt circle. Consult factory for specific bolt circle required.

Material

One-piece non-tapered round shaft of low carbon steel (ASTM-A500 Grade B, 42,000 PSI min. yield) with one flush-welded vertical seam. Shaft is welded to a flat steel anchor base (ASTM-36, 36,000 PSI min. yield). Wall thickness is 11 guage or 7 guage.

Mounting

Four anchor bolts provided are 1/2"x18" or 3/4"x18" depending on the pole height, fixture weight and mounting weight. Anchor bolts, nuts and washers are hot dipped galvanized steel. Spun aluminum bolt cover provided.

Access

All poles are provided with a hand access opening and cover. Hand hole cover is secured by two stainless steel machine screws. (Tamper-proof screws provided upon request).

Grounding

All poles are provided with an aluminum grounding lug integrated to inner wall of shaft, 180 degrees to hand hole. Grounding lug is drilled and tapped to accommodate 1/4-20 stainless steel machine screw.

Pole Height

Maximum pole height is 24-feet.

Accessories

Banner arms, ladder rests, signage, flag pole holder and GFI receptacles are optional.

Finish

A polyester powder coat high quality finish is electro-statically applied and baked at 430° for exceptional durability and color retention. Products undergo an intensive five-step cleansing and pretreatment process for maximum paint adhesion. Marine grade finish provides superior salt, humidity, and UV protection. This coating withstands up to 3000 hours of continuous salt spray, comes with a 5-year warranty and is available in either a textured or gloss surface.

SMOOTH STEEL BOLT DOWN POLE OPTIONS

Item Number	OD	Height	Wall
BD3STLS8-11	3.00"	8'	11g
BD3STLS10-11	3.00"	10'	11g
BD3STLS12-11	3.00"	12'	11g
BD3STLS14-11	3.00"	14'	11g
BD3STLS16-11	3.00"	16'	11g
BD3STLS18-11	3.00"	18'	11g
BD3STLS20-11	3.00"	20'	11g
BD3STLS8-7	3.00"	8'	7g
BD3STLS10-7	3.00"	10'	7g
BD3STLS12-7	3.00"	12'	7g
BD3STLS14-7	3.00"	14'	7g
BD3STLS16-7	3.00"	16'	7g
BD3STLS18-7	3.00"	18'	7g
BD3STLS20-7	3.00"	20'	7g
BD3STLS22-7	3.00"	22'	7g
BD3STLS24-7	3.00"	24'	7g
BD4STLS8-11	4.00"	8'	11g
BD4STLS10-11	4.00"	10'	11g
BD4STLS12-11	4.00"	12'	11g
BD4STLS14-11	4.00"	14'	11g
BD4STLS16-11	4.00"	16'	11g
BD4STLS18-11	4.00"	18'	11g
BD4STLS20-11	4.00"	20'	11g
BD4STLS8-7	4.00"	8'	7g
BD4STLS10-7	4.00"	10'	7g
BD4STLS12-7	4.00"	12'	7g
BD4STLS14-7	4.00"	14'	7g
BD4STLS16-7	4.00"	16'	7g
BD4STLS18-7	4.00"	18'	7g
BD4STLS20-7	4.00"	20'	7g
BD4STLS22-7	4.00"	22'	7g
BD4STLS24-7	4.00"	24'	7g